

SCRAILS®

SCRAIL FASCOAT

■ Technische Beschreibung

Code	Bezeichnung			
FasCoat - TX				
16S2550FSB	Scrail® 25/28 x 50 schwarz	2 000	96 000	221
16S2550FSR	Scrail® 25/28 x 50 rot	2 000	96 000	221

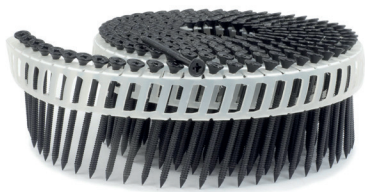

Code	Bezeichnung			
FasCoat - TX				
3425050FSB	Scrail® 34° 2,5 x 50 schwarz	2 200	165 000	413
3425050FSR	Scrail® 34° 2,5 x 50 rot	2 200	165 000	413



SCRAIL

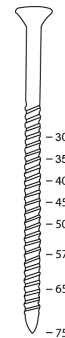

FC



Verwandte Produkte



Pneumatischer
Nagler C 28/50 P1
Code : **105C2850H**



Pneumatischer
Nagler C 38/90 P1
Code : **12C3890**



Pneumatischer
Nagler HOLZ HN 90 F
Code : **HN90F**

Weitere Informationen
auf unserer Website :





In Rollen

COILS 16°	FUSSAB-DRUCK	CODE	Ød1	Ød2	ØD	L	LG	X	NÄGEL PRO ROLLE
Scrail® 25/28 x 50 Schwarz	TORX 15	16S2550FSB	2,50	2,75	6,80	50,0	35,0	20	200
Scrail® 25/28 x 50 Rot	TORX 15	16S2550FSR	2,50	2,75	6,80	50,0	35,0	20	200

Die Dicke der Korrosionsschutzbehandlung ist nicht inbegriffen.

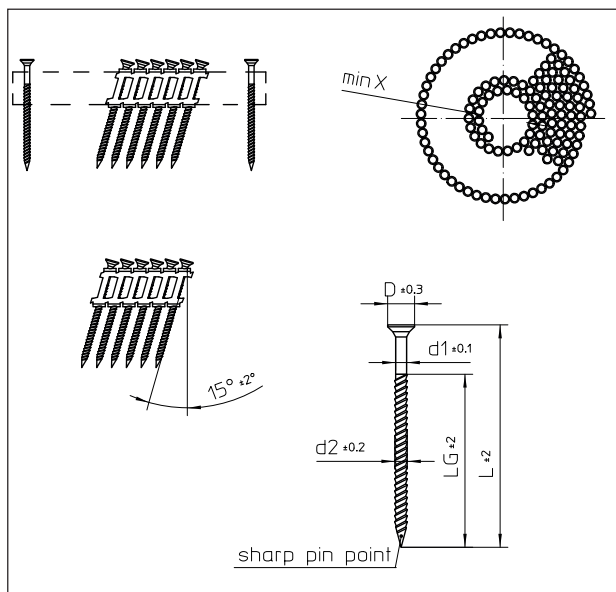

MATERIAL

T/S min.	1300 N/mm ²
Finishing	FasCoat

In Streifen

SCRAILS 34°	FUSSAB-DRUCK	CODE	Ød1	Ød2	ØD	L	LG	A	B	Y	X
Scrail® 25/28 x 50 schwarz	TORX 15	3425050FSB	2,50	2,75	6,80	50,0	35,0	23	34	34	25
Scrail® 25/28 x 50 Rot	TORX 15	3425050FSR	2,50	2,75	6,80	50,0	35,0	23	34	34	25

Die Dicke der Korrosionsschutzbehandlung ist nicht inbegriffen.

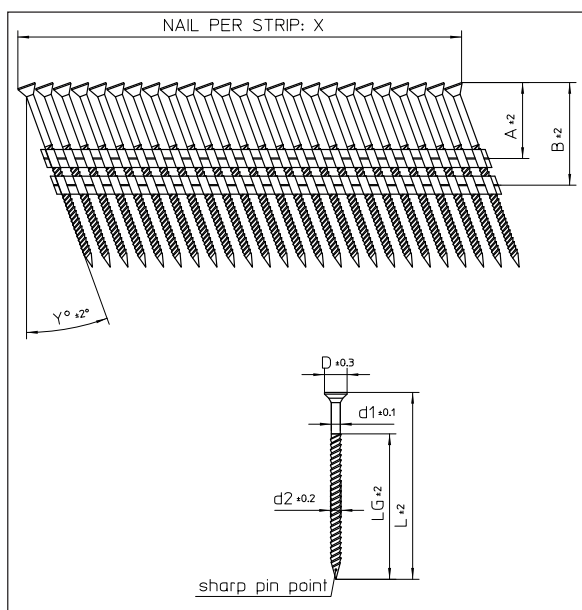

MATÉRIEL

T/S min.	1300 N/mm ²
Finishing	FasCoat

Die Angaben sind unverbindlich. Alsafix kann nicht haftbar gemacht werden, wenn die Anwendung ohne vorherige Berechnung und Prüfung des jeweiligen Falles erfolgt.